

jaga

CLIMATE DESIGNERS

Heating 

Light cooling 

STRADA HYBRID € 2021.EX

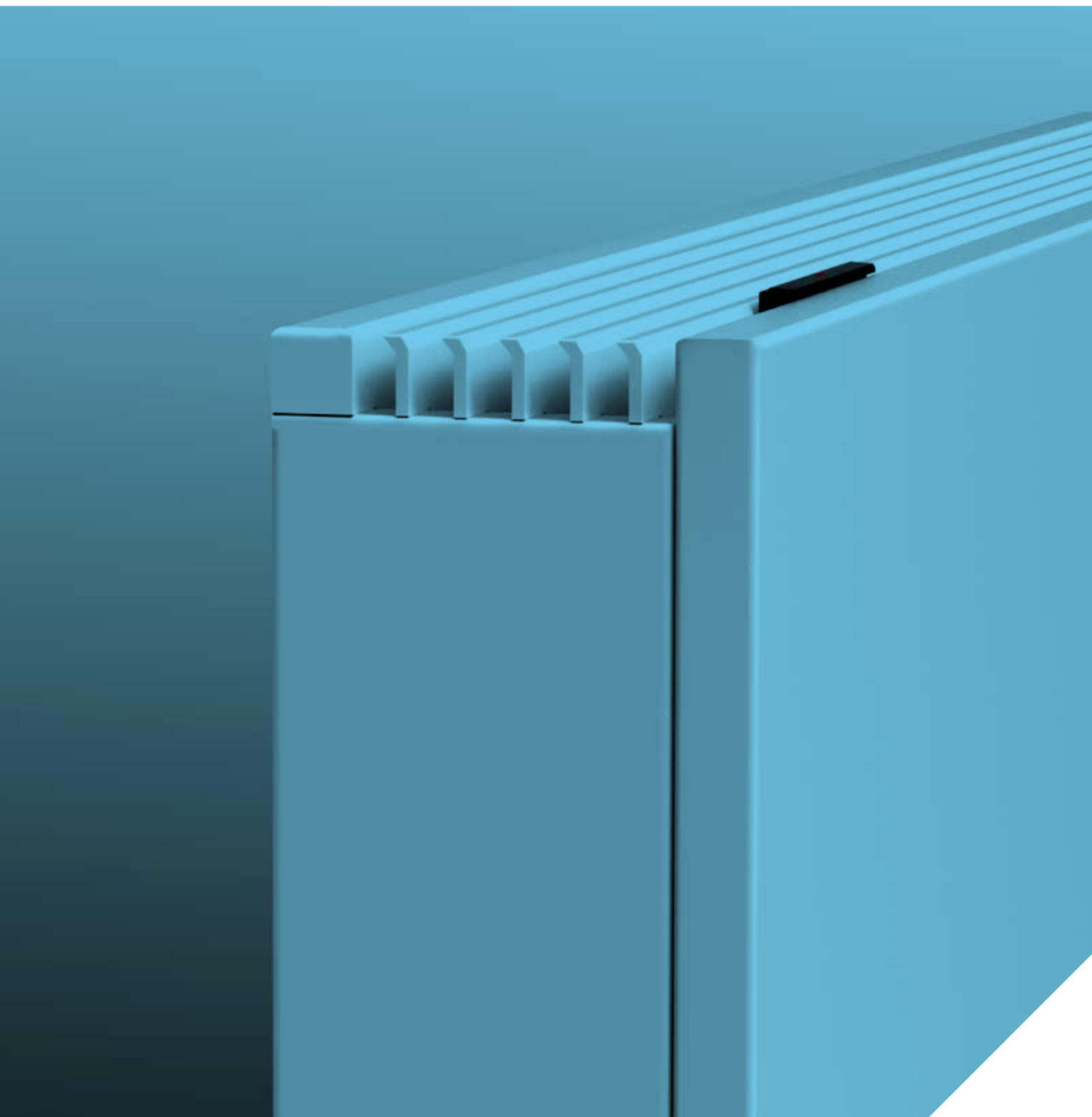

jaga

CLIMATE DESIGNERS

STRADA HYBRID

The most compact heating unit for heating or heating + cooling

Also suitable for Jaga Light cooling

- **Efficient and effortless heating with the lowest water temperature**
- **Energy-efficient non-condensing cooling in combination with any heat pump that can supply cooling water**
- **Improves the seasonal efficiency of each heat pump**
- **Makes sure that the condensing boilers are operating at their lowest temperature and as efficiently as possible.**

“From the designers of the first low temperature heater.”



Strada Hybrid T16
H50 x L120
● 55/45/20: 2754 Watts
● 16/18/27: 740 Watts





STRADA HYBRID



*Strada Hybrid T11
H35 x L100
55/45/20: 1600 Watts
Graphite black RAL 7021 color with Jaga AB thermostat head.*

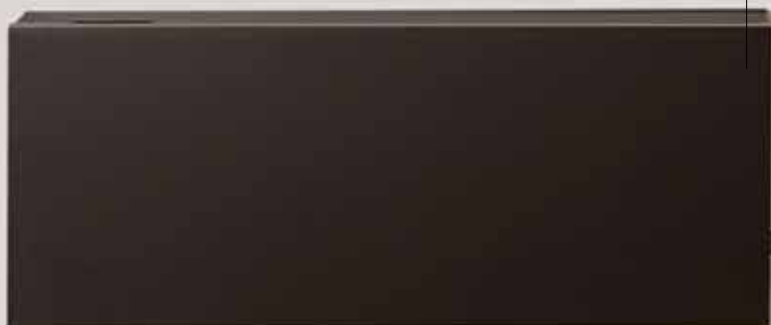

HEATING OR HEATING + LIGHT COOLING: THE IDEAL HEAT PUMP HEATING UNIT

HIGH OUTPUT WITH ALL WATER TEMPERATURES, HOT AND COLD

New, environmentally-friendly installations require much better thermal units. This ensures a comfortable temperature at a low water temperature and a refreshing coolness with non-condensing cooling. Jaga Hybrid heating units are equipped with the brand new DBH system, DB stands for Dynamic Boost, to considerably increase the power of the heater. The H of Hybrid stands for the dual effect: heating and cooling.

- perfectly controlled heating at the lowest water temperature thanks to the hybrid system's reaction speed
- by default, suitable for energy-efficient non-condensing cooling in combination with any heat pump.

MOST RESPONSIVE OUTPUT SYSTEM CRUCIAL FOR HEATING AND COOLING DOWN

Heating

Is the oven or dishwasher on? If the sun shines inside? Your home is a dynamic given with constantly changing temperature conditions and comfort requirements. A quickly reacting heater such as Strada Hybrid anticipates this and accurately controls the temperature in all circumstances.

Jaga light cooling

The reaction capacity is also crucial for non-condensing cooling. In order to prevent moisture problems, central condensation monitoring must be provided. This can only work efficiently with a very fast-acting delivery system, which immediately adjusts the cooling system in case of a sudden rise in humidity.

More than ever, the responsiveness determines your energy consumption and your comfort.

COMPARISON OF THE REACTION TIME IN CASE OF TEMPERATURE CHANGES

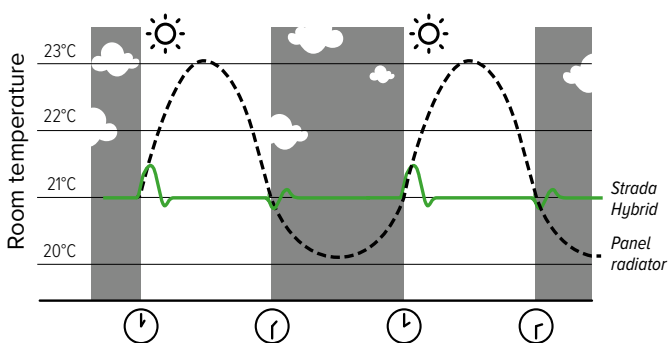

MULTIFUNCTIONAL INTELLIGENCE

Auto-change-over mode (Standard)

You do not have to do anything at all to switch between heating and cooling down. Due to its accurate room – and water temperature sensors, the hybrid is fully automated. To achieve the requested temperature you can set 3 different fan speeds, depending on the room where the heating unit is located: bedroom mode max. 26 dB(A), comfort mode max. 30 dB(A) or maximum mode for rapid heating and cooling.

With breeze feature

The Hybrid heater's DBH system can also be activated if there is no cooling water, so without a heat pump. The vicinity of the heater can already feel less warm with just the air movement of the fans.

IDEAL FOR RENOVATIONS AND A SWITCH TO A LOWER WATER TEMPERATURE NO LARGER HEATER REQUIRED

The lower the water temperature, the less heat the heater can emit. Extra large heating units are therefore required. But not so with the Strada Hybrid. The DBH system provides sufficient additional power, and you can now switch to a very low water temperature with identical dimensions. **That is why the Strada Hybrid is the very best heat pump heating unit.**

COMPARISON OF 850 WATTS AT 45/35/20 °C.

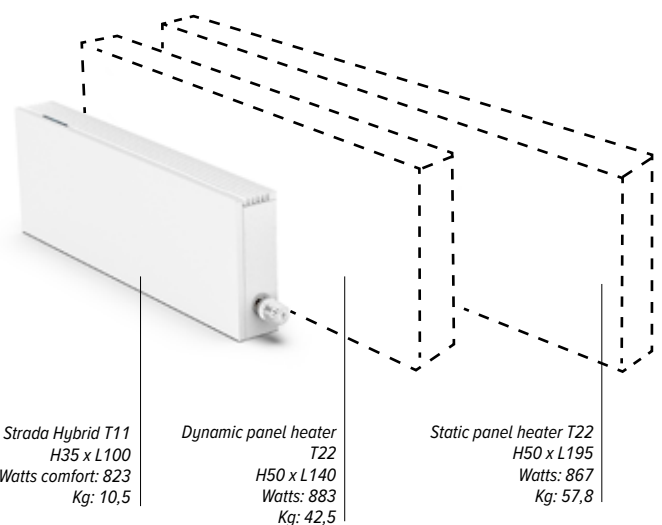

Tip: For all info on the Hybrid system see www.jaga.com/technology/heating/dbh.html

TECHNICAL INFORMATION

DIMENSIONS (in cm)

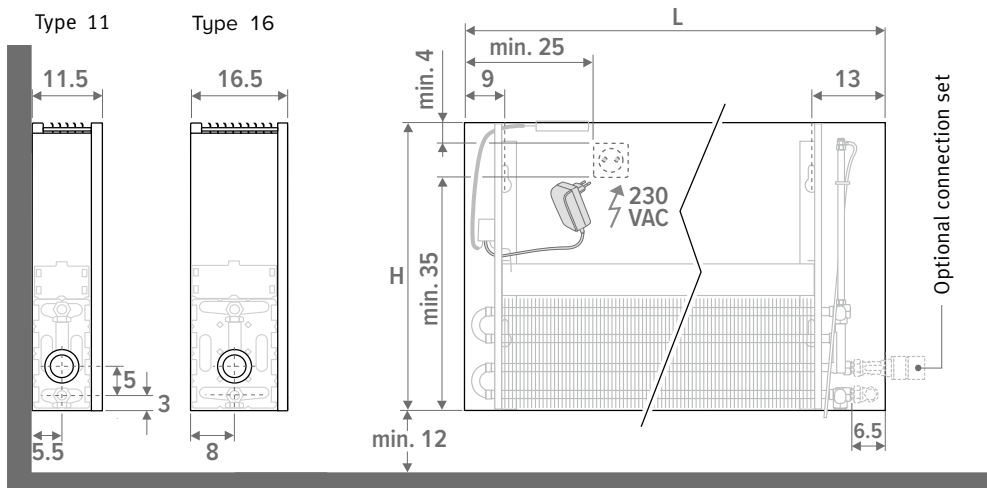

DELIVERY

Easy to install by one person. Delivered in a cardboard box, which can also be used as protection on site after installation.

Standard delivery:

- Low-H₂O heat exchanger with wall brackets and fixing kit, air vent 1/8" and drain plug 1/2"
- casing for connection left or right at low level
- cover plate in stainless steel effect for the side panel at the opposite end from the valve
- easy to install DBH-unit with operation, control and 24VDC power supply
- clear installation instructions

⚠ This heater is not equipped with a condensation monitor. It has to be integrated into the installation. (only for cooling)

COLOURS

Environmentally-friendly, scratch-resistant and UV-resistant powder coating.

Standard colours:

Colour 133: traffic white RAL 9016 soft touch lightly structured satin powder coating
 Colour 001: sandblast grey fine texture metallic powder coating

Other colours:

see colour chart on www.jaga.com

ELECTRICAL CONNECTION

The DBH system requires an electrical outlet near the heating unit. If it has a height of 50, 65 and 95 cm, an electrical outlet or power cable can be installed in the casing. If the height is 30 cm, only the power cable can be installed inside the casing. Connection to an external electrical outlet is always possible. Do not connect the electrical and hydraulic connection to the same side of the coil.

HYDRAULIC CONNECTION

Heating

Supply / return on the bottom left or right, to the wall or floor. Wall connection via bottom or completely invisible within the cladding with valve set 225/265.

Heating and cooling

The same connections and valve sets can be used for heating and cooling as for single heating. For the valve sets, use the version with the Heimeier thermostat head HC for heating and cooling or the version with a manual valve. It doesn't get any simpler!

OPERATION OF THE DBH SYSTEM

Strada Hybrid is by default equipped with the DBH-control in Auto-Change-Over mode. The desired room temperature is set via a room thermostat or the heating unit's thermostat head. The Strada Hybrid heater has accurate sensors for both the room and water temperature. DBH automatically switches between standby / heating / cooling based on the measured values.

- suitable for heating or heating and cooling with the thermostat head HC or the manual button MA.
- noise level monitoring, officially measured according to ISO 3741: 2010
- with breeze feature for a fan effect, does not depend on the water temperature.
- colored LEDs indicate the feature and the fan speed.

⚠ Het DBH-systeem will not control the heat pump or the boiler and therefore cannot replace a room thermostat

NOISE AND POWER ACCORDING TO THE LATEST EUROPEAN STANDARDS

The heat output of the Strada Hybrid was measured according to the latest European standards regarding heating units with integrated fans. Jaga is one of the first to comply with the new reference standard **EN 16430**.

The sound power (L_w) of the Strada Hybrid is measured in accordance with **ISO 3741:2010**. As is customary for the sound pressure (L_p), room attenuation of 8 dB(A) is assumed for room content of 100 m³ and a reverberation time of 0.5 sec.

HOW TO SELECT STRADA HYBRID

Strada Hybrid is selected in comfort mode, **position 2 in bold** in the output tables. This guarantees a quiet operation at a maximum of 30 dB(A). Position 1 is an extremely quiet bedroom setting with a maximum of 26 dB(A). Position 3 provides a maximum boost and the very high output serves primarily to heat up and cool down a room as quickly as possible. In this mode the noise is between 42 and 46 dB(A).

How loud is a decibel?

dB(A)	Perception	Examples
10	hardly to hear	breathing, a falling leaf
20	just audible	radio studio, rustling of tree leaves
30	very quiet	library (30 to 40), whispering
40	quiet	living room, quiet classroom, soft buzz, fridge
50	limited sound	air conditioning, normal conversation, dishwasher

OUTPUTS STRADA HYBRID

HEIGHT 035

DIMENSIONS			POSITION	HEATING Room temperature 20°C				COOLING Room temperature 27°C	SOUND PRESSURE dB(A)	ELECTRIC POWER CONSUMPTION W	PRICE Standard colours €	PRICE Other colours €	ORDER CODE			
H cm	L cm	B cm		75/65 Watts	55/45 Watts	45/35 Watts	35/30 Watts	16/18 Watts								
035	060	11	1	1142	647	409	246	191	26,0	4,8	592,00	667,00	STRW.035 060 11 /133 /ACO			
			2	1223	693	438	263	205	30,0	5,4						
			3	1447	819	518	311	242	40,0	6,8						
		16	1	1400	793	501	301	214	26,0	4,8				655,00	735,00	STRW.035 060 16 /133 /ACO
			2	1503	851	538	323	230	30,0	5,5						
			3	1989	1126	712	428	305	41,1	7,2						
	080	11	1	1648	933	589	355	276	26,0	6,3	671,00	753,00	STRW.035 080 11 /133 /ACO			
			2	1770	1002	633	381	296	30,0	6,8						
			3	2136	1210	764	460	358	41,8	9,1						
		16	1	2040	1156	730	439	312	26,0	6,0				756,00	849,00	STRW.035 080 16 /133 /ACO
			2	2188	1239	783	471	335	30,0	6,7						
			3	2936	1663	1050	632	450	42,4	9,0						
	100	11	1	2136	1210	764	460	358	26,0	7,8	791,00	884,00	STRW.035 100 11 /133 /ACO			
			2	2301	1303	823	495	385	30,0	8,7						
			3	2825	1600	1011	608	473	43,0	12,2						
		16	1	2630	1490	941	566	403	26,0	7,0				909,00	1012,00	STRW.035 100 16 /133 /ACO
			2	2817	1595	1008	606	431	30,0	7,7						
			3	3883	2199	1389	836	595	44,1	10,7						
120	11	1	2612	1479	935	562	437	26,0	8,9	870,00	977,00	STRW.035 120 11 /133 /ACO				
		2	2822	1598	1010	607	473	30,0	9,9							
		3	3514	1990	1257	756	589	44,0	14,8							
	16	1	3242	1836	1160	698	496	26,0	8,7				1003,00	1123,00	STRW.035 120 16 /133 /ACO	
		2	3472	1966	1242	747	532	30,0	9,8							
		3	4830	2735	1728	1039	740	44,8	14,3							
140	11	1	3077	1743	1101	662	515	26,0	10,1	947,00	1060,00	STRW.035 140 11 /133 /ACO				
		2	3333	1887	1192	717	558	30,0	11,2							
		3	4203	2380	1504	904	704	44,8	17,5							
	16	1	3844	2177	1376	827	589	26,0	9,6				1096,00	1222,00	STRW.035 140 16 /133 /ACO	
		2	4117	2332	1473	886	630	30,0	10,5							
		3	5777	3272	2067	1243	885	45,4	14,4							
160	11	1	3533	2001	1264	760	592	26,0	11,0	1152,00	1284,00	STRW.035 160 11 /133 /ACO				
		2	3835	2172	1372	825	642	30,0	12,4							
		3	4892	2771	1750	1053	819	45,5	19,2							
	16	1	4418	2502	1581	951	676	26,0	11,5				1348,00	1496,00	STRW.035 160 16 /133 /ACO	
		2	4717	2671	1688	1015	722	30,0	12,8							
		3	6724	3808	2406	1447	1030	46,4	19,6							
200	11	1	4423	2505	1582	952	741	26,0	13,4	1321,00	1482,00	STRW.035 200 11 /133 /ACO				
		2	4821	2730	1725	1037	807	30,0	14,8							
		3	6270	3551	2243	1349	1050	46,5	24,0							
	16	1	5667	3210	2028	1220	868	26,0	13,2				1594,00	1774,00	STRW.035 200 16 /133 /ACO	
		2	5971	3382	2137	1285	914	30,0	14,7							
		3	8618	4881	3083	1855	1320	47,1	23,5							
240	11	1	5238	2967	1874	1127	877	26,0	14,8	1637,00	1838,00	STRW.035 240 11 /133 /ACO				
		2	5738	3250	2053	1235	961	30,0	16,6							
		3	7648	4331	2736	1646	1281	47,2	28,0							
	16	1	6916	3917	2475	1488	1059	26,0	16,4				1989,00	2212,00	STRW.035 240 16 /133 /ACO	
		2	7168	4060	2565	1543	1098	30,0	17,7							
		3	10512	5953	3761	2262	1610	48,1	29,7							
280	11	1	5977	3385	2138	1286	956	26,0	16,2	1785,00	2011,00	STRW.035 280 11 /133 /ACO				
		2	6599	3737	2361	1420	1056	30,0	18,6							
		3	8790	4978	3145	1892	1406	47,8	31,4							
	16	1	8166	4625	2922	1757	1250	26,0	19,3				2200,00	2451,00	STRW.035 280 16 /133 /ACO	
		2	8348	4728	2987	1797	1278	30,0	20,4							
		3	12406	7026	4439	2670	1900	48,9	34,5							

Output measured in accordance with EN 16430

Standard colour: **133** (traffic white RAL 9016)
or **001** (sandblast grey)
Other colours see Jaga colour chart

OUTPUT EXPLANATION

HEATING CAPACITY
Due to the perfect combination of the DBH system and the extremely powerful Low-H₂O coil, the heater's height no longer influences the heat capacity. Thanks to the DBH system, maximum output is available for even the smallest heaters!

COOLING CAPACITY
The cooling capacity remains constant for all types with a maximum height of 50 cm. If the height exceeds 50 cm, the cooling capacity for types 11, 16 and 21 is reduced by approximately 5% for each additional 10 cm of height.



Tip: For all other dimensions, see www.jaga.com/Products/Horizontal/Strada/hybrid-ACO

OUTPUTS STRADA HYBRID

HEIGHT 050

DIMENSIONS			POSITION	HEATING Room temperature 20°C				COOLING Room temperature 27°C	SOUND PRESSURE dB(A)	ELECTRIC POWER CONSUMPTION W	PRICE		ORDER CODE
H cm	L cm	B cm		75/65 Watts	55/45 Watts	45/35 Watts	35/30 Watts	16/18 Watts			Standard colours €	Other colours €	
050	060	11	1	1142	647	409	246	191	26.0	4.8	607,00	690,00	STRW.050 060 11 /133 /ACO
			2	1223	693	438	263	205	30.0	5.4			
			3	1447	819	518	311	242	40.0	6.8			
	16	1	1400	793	501	301	214	26.0	4.8	670,00	757,00	STRW.050 060 16 /133 /ACO	
		2	1503	851	538	323	230	30.0	5.5				
		3	1989	1126	712	428	305	41.1	7.2				
080	11	11	1	1648	933	589	355	276	26.0	6.3	687,00	780,00	STRW.050 080 11 /133 /ACO
			2	1770	1002	633	381	296	30.0	6.8			
			3	2136	1210	764	460	358	41.8	9.1			
	16	1	2040	1156	730	439	312	26.0	6.0	775,00	877,00	STRW.050 080 16 /133 /ACO	
		2	2188	1239	783	471	335	30.0	6.7				
		3	2936	1663	1050	632	450	42.4	9.0				
100	11	11	1	2136	1210	764	460	358	26.0	7.8	810,00	913,00	STRW.050 100 11 /133 /ACO
			2	2301	1303	823	495	385	30.0	8.7			
			3	2825	1600	1011	608	473	43.0	12.2			
	16	1	2630	1490	941	566	403	26.0	7.0	928,00	1041,00	STRW.050 100 16 /133 /ACO	
		2	2817	1595	1008	606	431	30.0	7.7				
		3	3883	2199	1389	836	595	44.1	10.7				
120	11	11	1	2612	1479	935	562	437	26.0	8.9	891,00	1010,00	STRW.050 120 11 /133 /ACO
			2	2822	1598	1010	607	473	30.0	9.9			
			3	3514	1990	1257	756	589	44.0	14.8			
	16	1	3242	1836	1160	698	496	26.0	8.7	1026,00	1158,00	STRW.050 120 16 /133 /ACO	
		2	3472	1966	1242	747	532	30.0	9.8				
		3	4830	2735	1728	1039	740	44.8	14.3				
140	11	11	1	3077	1743	1101	662	515	26.0	10.1	971,00	1099,00	STRW.050 140 11 /133 /ACO
			2	3333	1887	1192	717	558	30.0	11.2			
			3	4203	2380	1504	904	704	44.8	17.5			
	16	1	3844	2177	1376	827	589	26.0	9.6	1123,00	1262,00	STRW.050 140 16 /133 /ACO	
		2	4117	2332	1473	886	630	30.0	10.5				
		3	5777	3272	2067	1243	885	45.4	14.4				
160	11	11	1	3533	2001	1264	760	592	26.0	11.0	1180,00	1331,00	STRW.050 160 11 /133 /ACO
			2	3835	2172	1372	825	642	30.0	12.4			
			3	4892	2771	1750	1053	819	45.5	19.2			
	16	1	4418	2502	1581	951	676	26.0	11.5	1379,00	1544,00	STRW.050 160 16 /133 /ACO	
		2	4717	2671	1688	1015	722	30.0	12.8				
		3	6724	3808	2406	1447	1030	46.4	19.6				
200	11	11	1	4423	2505	1582	952	741	26.0	13.4	1355,00	1535,00	STRW.050 200 11 /133 /ACO
			2	4821	2730	1725	1037	807	30.0	14.8			
			3	6270	3551	2243	1349	1050	46.5	24.0			
	16	1	5667	3210	2028	1220	868	26.0	13.2	1628,00	1828,00	STRW.050 200 16 /133 /ACO	
		2	5971	3382	2137	1285	914	30.0	14.7				
		3	8618	4881	3083	1855	1320	47.1	23.5				
240	11	11	1	5238	2967	1874	1127	877	26.0	14.8	1677,00	1900,00	STRW.050 240 11 /133 /ACO
			2	5738	3250	2053	1235	961	30.0	16.6			
			3	7648	4331	2736	1646	1281	47.2	28.0			
	16	1	6916	3917	2475	1488	1059	26.0	16.4	2029,00	2275,00	STRW.050 240 16 /133 /ACO	
		2	7168	4060	2565	1543	1098	30.0	17.7				
		3	10512	5953	3761	2262	1610	48.1	29.7				
280	11	11	1	5977	3385	2138	1286	956	26.0	16.2	1831,00	2083,00	STRW.050 280 11 /133 /ACO
			2	6599	3737	2361	1420	1056	30.0	18.6			
			3	8790	4978	3145	1892	1406	47.8	31.4			
	16	1	8166	4625	2922	1757	1250	26.0	19.3	2246,00	2525,00	STRW.050 280 16 /133 /ACO	
		2	8348	4728	2987	1797	1278	30.0	20.4				
		3	12406	7026	4439	2670	1900	48.9	34.5				

OUTPUT EXPLANATION

HEATING CAPACITY
Due to the perfect combination of the DBH system and the extremely powerful Low-H₂O coil, the heater's height no longer influences the heat capacity. Thanks to the DBH system, maximum output is available for even the smallest heaters!

COOLING CAPACITY
The cooling capacity remains constant for all types with a maximum height of 50 cm. If the height exceeds 50 cm, the cooling capacity for types 11, 16 and 21 is reduced by approximately 5% for each additional 10 cm of height.

Output measured in accordance with EN 16430

Standard colour: 133 (traffic white RAL 9016)
or 001 (sandblast grey)
Other colours see Jaga colour chart



Tip: For all other dimensions, see www.jaga.com/Products/Horizontal/Strada/hybrid-ACO

OUTPUTS STRADA HYBRID

HEIGHT 065

DIMENSIONS			POSITION	HEATING Room temperature 20°C				COOLING Room temperature 27°C	SOUND PRESSURE	ELECTRIC POWER CONSUMPTION	PRICE Standard colours	PRICE Other colours	ORDER CODE
H	L	B		75/65	55/45	45/35	35/30	16/18					
cm	cm	cm		Watts	Watts	Watts	Watts	Watts	dB(A)	W	€	€	
065	060	11	1	1142	647	409	246	177	26.0	4.8	623,00	714,00	STRW.065 060 11 /133 /ACO
			2	1223	693	438	263	189	30.0	5.4			
			3	1447	819	518	311	224	40.0	6.8			
	16	1	1400	793	501	301	198	26.0	4.8	690,00	787,00	STRW.065 060 16 /133 /ACO	
		2	1503	851	538	323	213	30.0	5.5				
		3	1989	1126	712	428	282	41.1	7.2				
	080	11	1	1648	933	589	355	255	26.0	6.3	706,00	810,00	STRW.065 080 11 /133 /ACO
			2	1770	1002	633	381	274	30.0	6.8			
			3	2136	1210	764	460	331	41.8	9.1			
		16	1	2040	1156	730	439	289	26.0	6.0	797,00	912,00	STRW.065 080 16 /133 /ACO
			2	2188	1239	783	471	310	30.0	6.7			
			3	2936	1663	1050	632	416	42.4	9.0			
	100	11	1	2136	1210	764	460	331	26.0	7.8	829,00	945,00	STRW.065 100 11 /133 /ACO
			2	2301	1303	823	495	357	30.0	8.7			
			3	2825	1600	1011	608	438	43.0	12.2			
		16	1	2630	1490	941	566	373	26.0	7.0	953,00	1079,00	STRW.065 100 16 /133 /ACO
			2	2817	1595	1008	606	399	30.0	7.7			
			3	3883	2199	1389	836	550	44.1	10.7			
120	11	1	2612	1479	935	562	405	26.0	8.9	915,00	1048,00	STRW.065 120 11 /133 /ACO	
		2	2822	1598	1010	607	437	30.0	9.9				
		3	3514	1990	1257	756	544	44.0	14.8				
	16	1	3242	1836	1160	698	459	26.0	8.7	1054,00	1200,00	STRW.065 120 16 /133 /ACO	
		2	3472	1966	1242	747	492	30.0	9.8				
		3	4830	2735	1728	1039	684	44.8	14.3				
140	11	1	3077	1743	1101	662	477	26.0	10.1	998,00	1140,00	STRW.065 140 11 /133 /ACO	
		2	3333	1887	1192	717	516	30.0	11.2				
		3	4203	2380	1504	904	651	44.8	17.5				
	16	1	3844	2177	1376	827	544	26.0	9.6	1154,00	1309,00	STRW.065 140 16 /133 /ACO	
		2	4117	2332	1473	886	583	30.0	10.5				
		3	5777	3272	2067	1243	818	45.4	14.4				
160	11	1	3533	2001	1264	760	547	26.0	11.0	1210,00	1377,00	STRW.065 160 11 /133 /ACO	
		2	3835	2172	1372	825	594	30.0	12.4				
		3	4892	2771	1750	1053	758	45.5	19.2				
	16	1	4418	2502	1581	951	626	26.0	11.5	1414,00	1595,00	STRW.065 160 16 /133 /ACO	
		2	4717	2671	1688	1015	668	30.0	12.8				
		3	6724	3808	2406	1447	952	46.4	19.6				
200	11	1	4423	2505	1582	952	685	26.0	13.4	1391,00	1590,00	STRW.065 200 11 /133 /ACO	
		2	4821	2730	1725	1037	747	30.0	14.8				
		3	6270	3551	2243	1349	971	46.5	24.0				
	16	1	5667	3210	2028	1220	803	26.0	13.2	1669,00	1889,00	STRW.065 200 16 /133 /ACO	
		2	5971	3382	2137	1285	846	30.0	14.7				
		3	8618	4881	3083	1855	1221	47.1	23.5				
240	11	1	5238	2967	1874	1127	812	26.0	14.8	1719,00	1967,00	STRW.065 240 11 /133 /ACO	
		2	5738	3250	2053	1235	889	30.0	16.6				
		3	7648	4331	2736	1646	1185	47.2	28.0				
	16	1	6916	3917	2475	1488	980	26.0	16.4	2078,00	2349,00	STRW.065 240 16 /133 /ACO	
		2	7168	4060	2565	1543	1015	30.0	17.7				
		3	10512	5953	3761	2262	1489	48.1	29.7				
280	11	1	5977	3385	2138	1286	885	26.0	16.2	1878,00	2156,00	STRW.065 280 11 /133 /ACO	
		2	6599	3737	2361	1420	977	30.0	18.6				
		3	8790	4978	3145	1892	1301	47.8	31.4				
	16	1	8166	4625	2922	1757	1156	26.0	19.3	2299,00	2606,00	STRW.065 280 16 /133 /ACO	
		2	8348	4728	2987	1797	1182	30.0	20.4				
		3	12406	7026	4439	2670	1757	48.9	34.5				

Output measured in accordance with EN 16430

Standard colour: **133** (traffic white RAL 9016)
or **001** (sandblast grey)
Other colours see Jaga colour chart

OUTPUT EXPLANATION

HEATING CAPACITY
Due to the perfect combination of the DBH system and the extremely powerful Low-H₂O coil, the heater's height no longer influences the heat capacity. Thanks to the DBH system, maximum output is available for even the smallest heaters!

COOLING CAPACITY
The cooling capacity remains constant for all types with a maximum height of 50 cm. If the height exceeds 50 cm, the cooling capacity for types 11, 16 and 21 is reduced by approximately 5% for each additional 10 cm of height.



Tip: For all other dimensions, see www.jaga.com/Products/Horizontal/Strada/hybrid-ACO

OUTPUTS STRADA HYBRID

HEIGHT 095

DIMENSIONS			POSITION	HEATING Room temperature 20°C				COOLING Room temperature 27°C	SOUND PRESSURE dB(A)	ELECTRIC POWER CONSUMPTION W	PRICE Standard colours €	PRICE Other colours €	ORDER CODE
H cm	L cm	B cm		75/65 Watts	55/45 Watts	45/35 Watts	35/30 Watts	16/18 Watts					
095	060	11	1	1142	647	409	246	148	26.0	4.8	646,00	751,00	STRW.095 060 11 /133 /ACO
			2	1223	693	438	263	159	30.0	5.4			
			3	1447	819	518	311	188	40.0	6.8			
	16	1	1400	793	501	301	166	26.0	4.8	719,00	833,00	STRW.095 060 16 /133 /ACO	
		2	1503	851	538	323	178	30.0	5.5				
		3	1989	1126	712	428	236	41.1	7.2				
080	11	11	1	1648	933	589	355	214	26.0	6.3	734,00	854,00	STRW.095 080 11 /133 /ACO
			2	1770	1002	633	381	230	30.0	6.8			
			3	2136	1210	764	460	277	41.8	9.1			
	16	1	2040	1156	730	439	242	26.0	6.0	830,00	963,00	STRW.095 080 16 /133 /ACO	
		2	2188	1239	783	471	260	30.0	6.7				
		3	2936	1663	1050	632	348	42.4	9.0				
100	11	11	1	2136	1210	764	460	277	26.0	7.8	865,00	1002,00	STRW.095 100 11 /133 /ACO
			2	2301	1303	823	495	299	30.0	8.7			
			3	2825	1600	1011	608	367	43.0	12.2			
	16	1	2630	1490	941	566	312	26.0	7.0	994,00	1144,00	STRW.095 100 16 /133 /ACO	
		2	2817	1595	1008	606	334	30.0	7.7				
		3	3883	2199	1389	836	461	44.1	10.7				
120	11	11	1	2612	1479	935	562	339	26.0	8.9	955,00	1112,00	STRW.095 120 11 /133 /ACO
			2	2822	1598	1010	607	366	30.0	9.9			
			3	3514	1990	1257	756	456	44.0	14.8			
	16	1	3242	1836	1160	698	385	26.0	8.7	1100,00	1273,00	STRW.095 120 16 /133 /ACO	
		2	3472	1966	1242	747	412	30.0	9.8				
		3	4830	2735	1728	1039	573	44.8	14.3				
140	11	11	1	3077	1743	1101	662	399	26.0	10.1	1048,00	1221,00	STRW.095 140 11 /133 /ACO
			2	3333	1887	1192	717	433	30.0	11.2			
			3	4203	2380	1504	904	546	44.8	17.5			
	16	1	3844	2177	1376	827	456	26.0	9.6	1210,00	1399,00	STRW.095 140 16 /133 /ACO	
		2	4117	2332	1473	886	489	30.0	10.5				
		3	5777	3272	2067	1243	685	45.4	14.4				

OUTPUT EXPLANATION

HEATING CAPACITY
Due to the perfect combination of the DBH system and the extremely powerful Low-H₂O coil, the heater's height no longer influences the heat capacity. Thanks to the DBH system, maximum output is available for even the smallest heaters!

COOLING CAPACITY
The cooling capacity remains constant for all types with a maximum height of 50 cm. If the height exceeds 50 cm, the cooling capacity for types 11, 16 and 21 is reduced by approximately 5% for each additional 10 cm of height.

Output measured in accordance with EN 16430

Standard colour: 133 (traffic white RAL 9016)
or 001 (sandblast grey)
Other colours see Jaga colour chart



Tip: For all other dimensions, see www.jaga.com/Products/Horizontal/Strada/hybrid-ACO

NOTES

jaga
CLIMATE
DESIGNERS

Jaga International
Verbindingslaan 16
B-3590 Diepenbeek

Tel.: +32 (0)11 29 41 12
Fax: +32 (0)11 29 41 60
export@jaga.com

The information in this price list is correct at the time of printing.
Jaga reserves the right to change product specification at any time in line
with our policy of continuous improvement and innovation.
All prices in Euro, exclude VAT. Prices valid from July 1, 2021.
Replaces all existing price lists.